

RF-2900

RF WIRELESS DATA TERMINAL

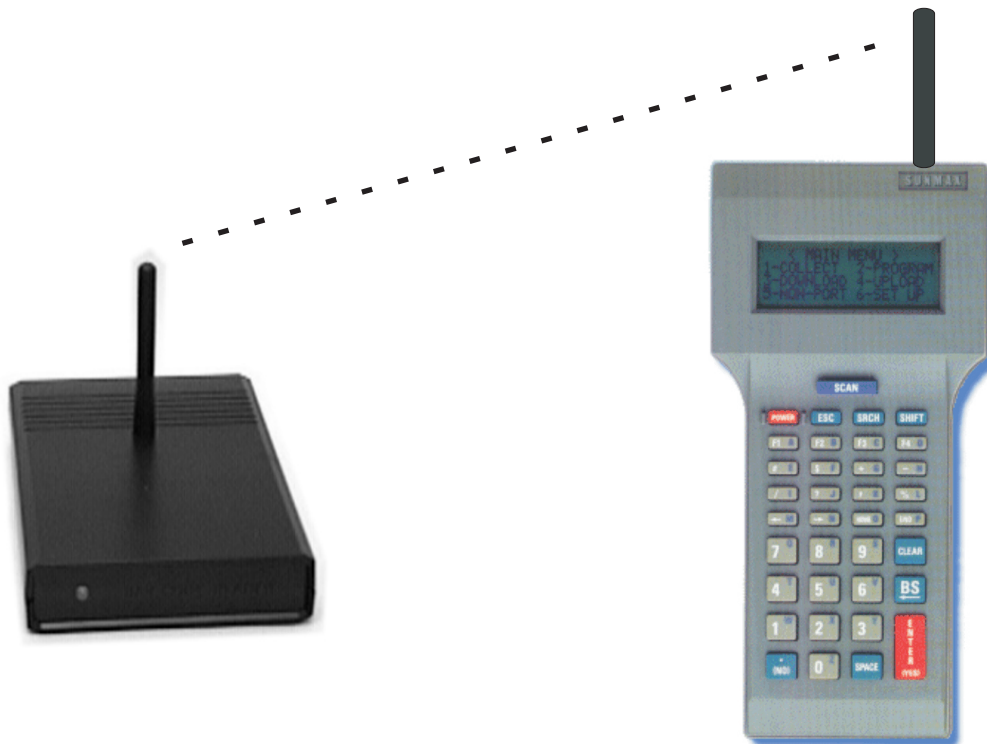

User's Manual

INSTRUCTION TO USER

This equipment contain an RF module which has been previously tested and found to be comply with the limits for a Class B digital device, pursuant to Part 15 of the FCC Rules. These limits are designed to provide reasonable protection against harmful interference in a residential installation. This equipment generates, uses and can radiate radio frequency and if not installed and used in accordance with the instructions, my cause harmful interference to radio communications. However, there is no guarantee that interference will not occur in a particular installation. If this equipment does cause harmful interference to radio or television reception, which can be determined by turning the equipment off and on, the user is encouraged to try to correct the interference by one or more of the following measures:

Reorient or relocate the receiving antenna

Increase the separation between the equipment and receiver

Connect the equipment into an outlet on a circuit different from that to which the receiver is connected.

Consult the dealer or an experienced radio/TV technician for help

This equipment has been certified to comply with the limits for a Class B computing device, pursuant to FCC Rules. In order to maintain compliance with FCC regulations, shielded cables must be used with this equipment. Operation with non-approved equipment or unshielded cables is likely to result in interference to radio and TV reception. The user is cautioned that changes and modifications made to the equipment without approval of manufacturer could void the user's authority to operate this equipment.

NOTE: D900SS-20 Module is pre-approved by the FCC for operation within the United States; however, they are not approved by other agencies worldwide. The purchaser should understands that additional approvals my be required prior to the sale or operation of the device, and agrees to utilize the component in keeping with all applicable laws in the country of operation.

Question regarding domestic rules should be addressed to:

Federal Communications Commission
Equipment Authorization Division
Customer Service Branch, MS 1300F2
7435 Oakland Mills Road
Columbia, MD 12046

Tel: 301-725-1585 Fax: 301-344-2050 E-Mail: labinfo@fcc.gov

TABLE OF CONTENTS

CHAPTER 1 INTRODUCTION	3
CHAPTER 2 GETTING STARTED	5
2.1 Install the Base Unit	5
2.2 Install the Portable Terminal	7
2.2.1 Site Survey	7
2.3 Scanning technique	8
CHAPTER 3 SETTING UP	9
3.1 Setting up the Base Unit	9
3.2 Setting up the Portable Terminal	11
3.2.1 Description of each topic	12
CHAPTER 4 PROGRAMMING	17
4.1 Host to Terminal Programming	18
4.2 Sample Routine in VISUAL BASIC	20
APPENDIX	22
A Communication protocol among RF-900, BASE and PC	22
B Specifications	23
C Summary of bar code types	24
D Pinout of the Host port and Relay port.....	25

CHAPTER 1 INTRODUCTION

The RF-900 is a rugged, user friendly, low-cost radio frequency portable terminal that provides powerful features for efficient bar code reading and keypad data entry remotely from your host computer. The RF technology used in RF-2900 is spread spectrum, frequency hopping which will not interfere with other RF equipment.

MENU-DRIVEN OPERATION

When you power up the RF-2900, you will see the MAIN MENU which is comprised of three Menus:

RF-TERMINAL

In this menu, the user may login the host computer, receive prompt, message, command and data from the host, and transmit bar code or keypad entry data to the host.

SITE SURVEY

In this menu, you may walk around your office or warehouse to make sure that the base unit covers the area you expect, or you may add satellite units to have more area covered.

SET UP

In this menu, you may configure Bar Code Symbologies, Terminal ID, Frequency Channel, Beep Tone, Terminator, Scanning Mode, and Function Keys.

4 NETWORK CHANNELS AVAILABLE

There are 4 network channels available. In the same location, user may use up to 4 Base Unit which are operated independly .

TERMINAL ID

Each RF-2900 will be assigned an ID to the base unit. The data sent to the host from the terminal have a header with the ID information in it. The data sent from the host to the terminal also need to include a header with the terminal ID information in it.

VERSATILE INPUT DEVICES

The RF-2900 can auto-discriminate between all the popular bar code symbologies: Code 39, UPC/EAN, Codabar, Interleaved 2 of 5, MSI/Plessy and Code 128. It come with a built-in Symbol laser engine. It also can support all types of bar code input devices such as: Wand, CCD, Laser scanner or magstripe scanner.

MULTIPLE POWER SOURCE

The RF-2900 can be operated with 3 AA batteries for portable operation, or with

an external power adapter when used as a fixed terminal.

LONG BATTERY LIFE

3 AA Alkaline batteries can give you approximately 36,000 scans with a laser scanner. That's nearly 8-10 hours of continuous use of the terminal.

BASE UNIT

Up to 8 of the RF-2900's can be controlled with a base unit. The base unit attaches to the serial port of the host computer. The base unit will receive the data from terminals and then pass to the host. Meanwhile, the base unit receives the prompt, message, command and data from the host and sent to certain RF-2900.

PROGRAMMING THE RF-2900

It requires programming on the host so that the host can talk to the RF-2900's through the serial port. No matter what programming language you are using, as long as you can access the serial port, you may use the RF-2900. This programming for accessing the serial port is relatively easy; the main effort would be to develop the application code.

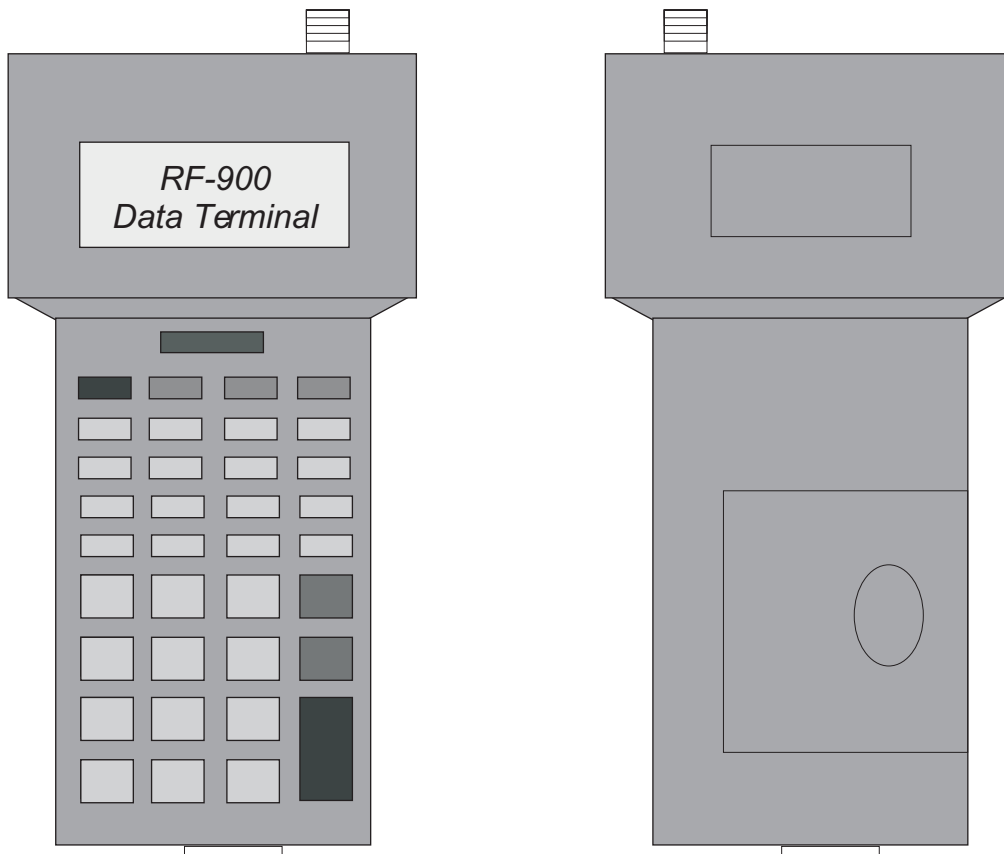

CHAPTER 2 GETTING STARTED

2.1 Installing the Base Unit to the RS-232 serial port

For proper installation, please refer to Fig 2.2 and adhere to the following steps:

1. Screw in the antenna to the Base unit
2. Plug the wall power unit into a wall outlet and the power jack into the Base Unit. You should hear four beeps - two low and two high, and see the LED illuminate from Yellow to green. That means the Base Unit is ready.
3. Connect the HOST port of the Base Unit to the COM port using the DB9-DB9 or DB9-DB25 cable.
4. Install the window based program RFAPP to your computer, then click Start, Programs and then RFAPP to run this demo program. The VISUAL BASIC source code is under the SOURCE sub-directory.

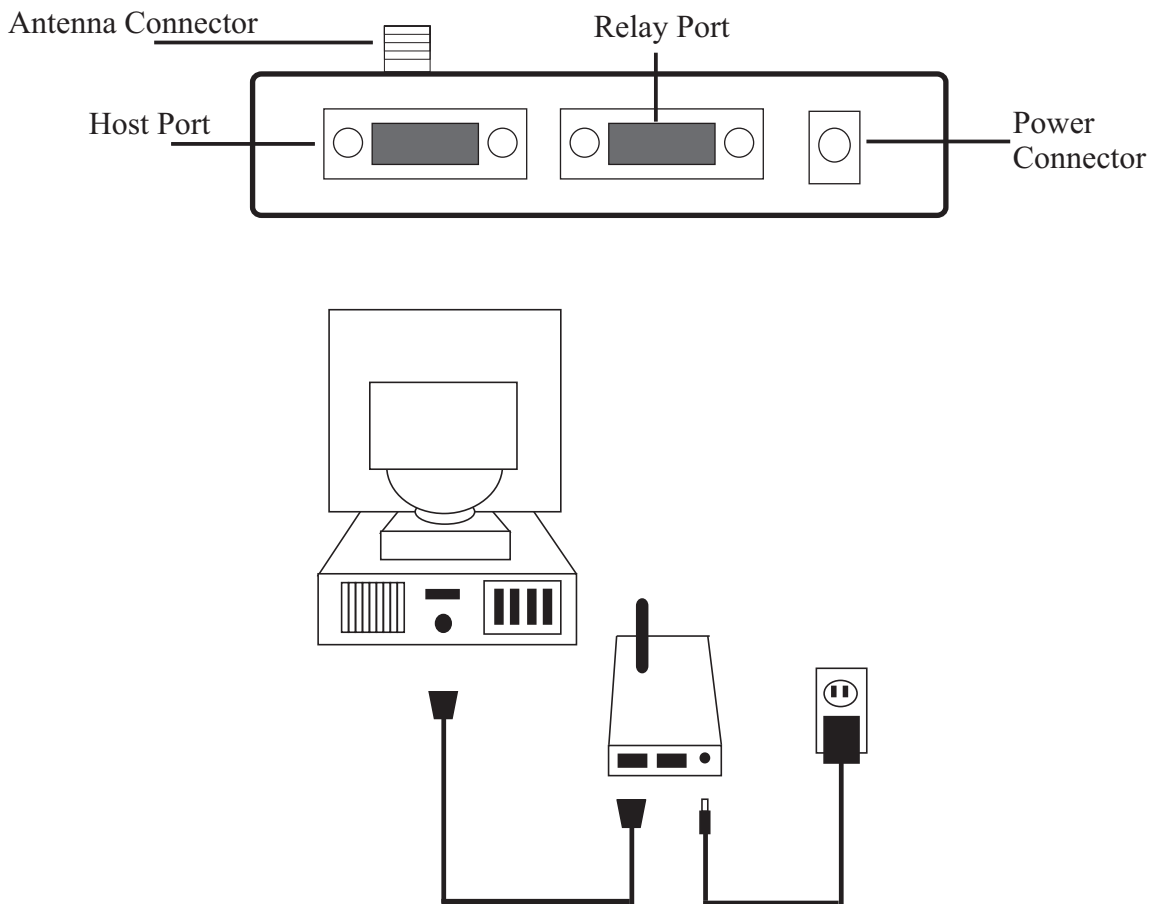

Fig 2.2 Installing the Base Unit to the RS-232 serial port

2.2 Installation the Portable Terminal

1. Open the battery door on the back of the Portable Terminal, install 3 AA batteries then close the battery door.
2. Power on the Portable Terminal by pressing and quick releasing the POWER key. You should hear a beep and see the MAIN MENU on the screen.
4. Press 1 to the RF TERMINAL Menu. You should see on the LCD display as follow:

WAITING FOR PROMPT
LOGIN... PLEASE WAIT

HIT ESC TO ABORT

<INVENTORY >
ITEM #: _

QTY:

Scan S MX1 0 0

<INVENTORY>
ITEM #: SMX100
KB Wedge Reader
QTY.: _

Key-in 22 then press ENTER Key

<INVENTORY >
ITEM #: _

QTY:

Scan S MX5 0 0

<INVENTORY>
ITEM #: SMX500
RS232/485 Reader
QTY.:

Key-in 132 then press ENTER Key

After you enter the quantity from the terminal, you should see the updated quantity on the computer. You may press ESC key to logout from the Host computer, and click Exit to terminate the demo program.

2.3 Site Survey

In this menu, you may walk around your office or warehouse to make sure that the base unit covers the area you expect. When doing the site survey, if the portable terminal keeps on beeping and shows "HOST IN RANGE" on the LCD display, that means the Base Unit is communicating with the Portable Terminal; otherwise, it is out of range.

2.4 Scanning technique

Using the built-in laser scanner

When using the RF-900 with a built-in laser scanner, hold the RF-900 on your palm, aim at the bar code label and press SCAN key with your thumb. Make sure the scan beam crosses all the bars and spaces on the label. If you had a successful read, you will hear a beep and see the correct message of the bar code label displayed on the portable terminal.

Using the Bar Code Wand

To use the magstripe scanner, you need to setup the portable terminal to DON'T USE SCAN KEY. (Refer to page 14 K-Scanning Mode). Then, plug the DB9 connector on the wand into the HOST port on the portable terminal. Hold the Wand as you do a pencil. The angle between the Wand and label surface should be in the range of 45 to 90 degrees.

To read a bar code label, place the tip of the wand near the label in the white area to the right or to the left of the bar code label. Draw an imaginary line with even speed through the entire label without stopping. Don't press the wand too hard to the bar code label or you might scratch the label. If you had a successful read, you will hear a beep and see the correct message of the bar code label displayed on the portable terminal.

While scanning the bar code label, the wand must stay within the label and pass over every bar and space of the label. Insufficient scanning will not give you a successful read.

Using the CCD scanner

Plug the DB9 connector on the CCD scanner into the HOST port on the portable terminal. Hold it up to the bar code and press the bottom. If you had a successful read, you will hear a beep and see the correct message of the bar code label displayed on the portable terminal. CCD scanner is a fixed width device - It can not read the label which is bigger than its width.

Using the Laser Scanner

Plug the DB9 connector on the laser scanner into the HOST port on the portable terminal. Hold the Laser Scanner as you do a toy gun. Aim at the bar code label and pull the trigger. Make sure the scan beam crosses all the bars and spaces on the label. If you had a successful read, you will hear a beep and see the correct message of the bar code label displayed on the portable terminal.

Using the magstripe scanner

To use the magstripe scanner, you need to setup the portable terminal to ENABLE MAGSTRIPE. (Refer to page 14 K-Scanning Mode). Then, Plug the DB9 connector on the magstripe scanner into the HOST port on the portable terminal. The reader can read track 1 or 2 single track. When reading the card, orient it so that the magstripe is facing the read head. Then, swipe the magstripe card through the entire slot. If you had a successful read, you will hear a beep and see the correct message displayed on the portable terminal.

3.2 Setting up the Portable Terminal

The Setup menu allows you to configure the Portable Terminal to meet your specific needs. From the SETUP MENU, first you select the topic, or press the **SPACE** key to view the selections, then enter the setup for the topic. For example, you may Enable Code 128 and Enable check digit & transmit it.

<MAIN MENU>
1- RF TERMINAL
2- SITE SURVEY
3- SET UP

Press **3** key to select SET UP MENU

< SETUP MENU >
ENTER SELECTION: _

HIT SP FOR OPTIONS

Press **H** key to setup the Code 128

< CODE 128 >
NOW-BE
_

HIT SP FOR OPTIONS

Press **SP** key to look up the options

A- ENABLE C128
B- DISABLE C128
C- ENABLE TRANS CHK
D- ENABLE CHK DIGIT

Press **ESC** key

< CODE 128 >
NOW-BE
_

HIT SP FOR OPTIONS

Press **A** key, **C** key then **ENTER** key

< SETUP MENU >
ENTER SELECTION: _

HIT SP FOR OPTIONS

Select other option or press **ESC** key to go to the MAIN MENU. Use the sequence above to configure the Portable Terminal to your needs. In the next section, we will describe each topic in detail.

3.2.1 Description of each topic

(A)-Code 39 *: Default setup,

- * A- Enable Code 39
- B- Disable Code 39
- * C- Enable full ASCII
- D- Disable full ASCII
- E- Transmit start/stop
- * F- Don't transmit start/stop
- G- Enable Mod 43 & transmit it
- H- Enable Mod 43 but don't transmit it
- * I- Disable Mod 43
- * J- Enable accumulate mode
- K- Disable accumulate mode

For information regarding Code 39, please see APPENDIX C.

(B)-UPC/A *: Default setup

- * A- Enable UPC/A
- B- Disable UPC/A
- * C- Transmit NSC
- D- Don't transmit NSC
- * E- Transmit check digit
- F- Don't transmit check digit
- G- Enable 2-digit supplement
- H- Enable 5-digit supplement
- * I- Disable supplement
- J- Transmit extra leading 0 (UPC/A = EAN13)
- * K- Don't transmit extra leading 0

For information regarding UPC/A, please see APPENDIX C.

(C)-UPC/E *: Default setup

- * A- Enable UPC/E with NSC 0
- B- Enable UPC/E with NSC 1

- C- Disable UPC/E
- D- Transmit NSC
- * E- Don't transmit NSC
- F- Transmit check digit
- * G- Don't transmit check digit
- H- Enable 2-digit supplement
- I- Enable 5-digit supplement
- * J- Disable supplement
- K- Expanded UPC/E (UPC/E = UPC/A)
- * L- Regular UPC/E

For information regarding UPC/E, please see APPENDIX C.

(D)-EAN *: Default setup

- * A- Enable EAN
- B- Disable EAN
- * C- Transmit flags (first 2 digits)
- D- Don't transmit flags
- * E- Transmit check digit
- F- Don't transmit check digit
- G- Enable 2-digit supplement
- H- Enable 5-digit supplement
- * I- Disable supplement
- J- Expanded EAN/8 with 5 leading 0's (= EAN13)
- * K- Regular EAN/8

For information regarding EAN, please see APPENDIX C.

(E)-Interleaved 2 of 5 *: Default setup

- A- Enable I25
- * B- Disable I25
- C- Enable check digit & transmit it
- D- Enable check digit but don't transmit it
- * E- Disable check digit

- * F- First read fix length
- G- User defined length
- H- Variable length

Since Interleave 2 of 5 bar code symbology is susceptible to partial reads. You need to define the length of the code to avoid this. There are two ways to define the length of the code. The first way is automatically set after the first successful read. Once the length is set, any code with a different length cannot be read by the reader. Another way of defining the I25 length is in SETUP MENU, "Interleaved 2 of 5 length" on page 15.

If you want to read Interleaved 2 of 5 bar code labels with different length, you may select the Variable length. But be careful of getting a partial read.

For more information regarding Interleaved 2 of 5, please see APPENDIX C.

(F)-Codabar *: Default setup

- A- Enable regular Codabar
- B- Enable CLSI Codabar
- * C- Disable Codabar
- D- Transmit start/stop
- * E- Don't transmit start/stop

For information regarding Codabar, please see APPENDIX C.

(G)-MSI Code *: Default setup

- A- Enable MSI with 1 mod 10 check digit
- B- Enable MSI with 2 mod 10 check digits
- C- Enable MSI with mod 11/mod 10 check digit
- * D- Disable MSI
- E- Transmit 1 check digit
- F- Transmit 2 check digits
- * G- Don't transmit check digit

For information regarding MSI Code, please see APPENDIX C.

(H)-Code 128 *: Default setup

- A- Enable Code 128
- * B- Disable Code 128
- C- Enable check digit & transmit it
- D- Enable check digit but don't transmit it
- * E- Disable check digit

For information regarding Code 128, please see APPENDIX C.

(I)-Terminal ID *: Default setup

- * A- 1
- B- 2
- C- 3
- D- 4
- E- 5
- F- 6
- G- 7
- H- 8

The portable terminal must be assigned an ID which matches the ID on the Base Unit. There are 8 ID codes available which means you may have up to 8 systems in the same location.

(J)-Network Channel

- A- # 1
- B- # 2
- C- # 3
- D- # 4

The Network channel on the Portable Terminal must match the frequency channel on the Base Unit.

(K)-Beep Tone *: Default setup

- A- Disable
- B- Low
- * C- Medium
- D-High

You can select the beeper frequency you feel is appropriate, or even disable the beeper if it's too noisy.

(L)-Termination Character*: Default setup

- A- None
- * B- CR
- C- HT
- D- CR/LF

After you have a successful read, the Portable Terminal append the termination character you select to the bar code information you read and transmits them to the Base Unit. There are four termination characters: None, Carriage Return, Horizontal Tab, Carriage Return/Line Feed.

Note: Termination character applies when the No. of Prompts is 0; when other than 0, the Preamble and Postamble defined in String 2 will be added to the data when uploading.

(M)- Scanning Mode *: Default setup

- * A- Regular Scanning
- B- Continuous Scanning
- * C- Disable Magstripe
- D- Enable Magstripe
- * G- Use SCAN key
- H- Don't use SCAN key

Regular scanning mode

In this mode, you pull the trigger to enable the scan beam. The scan beam will be off after you had a successful read. Then you need to pull the trigger again to scan the next bar code label.

Continuous scanning mode

In this mode, you pull the trigger to enable the scan beam. The scan beam will stay on and you may continuously scan bar code labels until you release the trigger.

Disable/Enable Magstripe

When using a magstripe reader with the IBS-800, you need to enable the Magstripe.

Use laser scanner/wand

When using a wand with the Portable Terminal, set to H- Use wand; when using a laser or CCD scanner, set to G- Use laser scanner.

(N)- Interleaved 2 of 5 length

First, you need to set the Interleaved 2 of 5 option to G - User Defined Length. Then, you set the length of Interleaved 2 of 5 by enter a two digit number.

(O)- Host Response Delay

You may set up the Host Response Delay time to which determine the waiting period between terminal sending data to the host and the host response back the prompt and command to the terminal. If the host doesn't response in this waiting period, the terminal will beep and display "HOST NO RESPONSE, HIT A KEY TO RETRY". You may hit a key to re-send the data or hit ESC to log-out. The setting of the Host Response Delay can be 00 - 99 which determine the delay of 0.5 - 50 second. The formula to calculate the delay time is $(N * 0.5) + 0.5$ second. N is the setting value.

(P)/(Q)/(R)/(S)- F1/F2/F3/F4 key definition

You may define up to four function keys, F1 - F4. Each key can be defined as a data string with up to 16characters.

(T)-Default Setup

This will Reset all the topics back to default. To prevent any unauthorized resetting, users need to enter the hard coded password - SUNMAX to access this function.

(U)/(V)/(W)-I25 Length 1/2/3

If you configure to Variable Length for I25, you may define up to 3 different bar code length.

(X)-Channel Group

There are 3 channel groups you can select. The group you select has to be the same as the one in the Base Unit.

Chapter 4 Operational Theory

In this chapter, we will describe how the RF-900 terminal works with Base Unit and the Host computer. In 4-1, we will state how the data transfer among RF-900, Base Unit and the Host when terminal log-in, host sends prompt /command to the terminal, terminal send data to the Host, terminal log-out, and terminal request for prompt/command. In 4-2, we will be focus on the prompt/command format sent from the Host to the terminal

4-1 Data Transfer among RF-900, Base Unit, and Host.

Terminal log-in

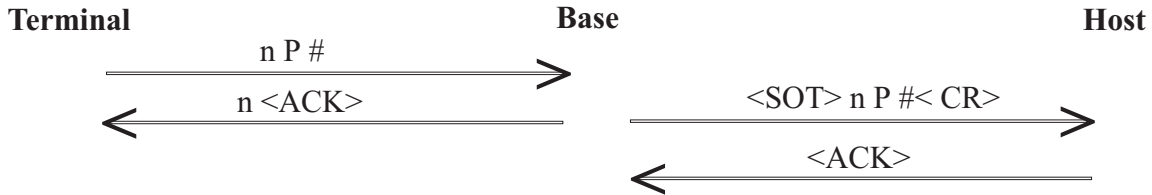

Once the RF-900 entered into RF terminal mode, it sends a log-in string to the base unit. Base Unit will return an ACK. If RF-900 doesn't receive the ACK in 1/2 second, it will beep and display "OUT OF RANGE, HIT A KEY TO RETRY". When RF-900 receive the ACK, it will display "WAITING FOR PROMPT". If RF-900 doesn't receive the Prompt from the Host in the time period defined in Host Response Delay (See page 15), it will display "HOST NO RESPONSE, HIT A KEY TO RETRY"

Base Unit sends the log-in string starting with an ASCII 2 to the Host. The Host has to return an ACK right after receiving the string. Otherwise, the Base Unit will send again.

- <SOT> is ASCII 2
- n is terminal ID, can be from 1 to 8.
- <CR> is the carriage return.

Host sends Prompt to terminal

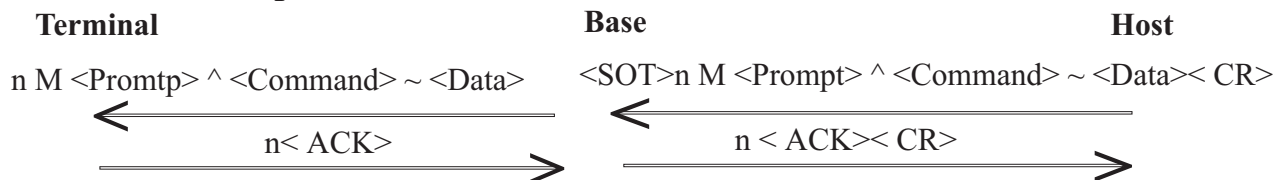

Host sends the Prompt/command string to the Base Unit as:

<SOT>n M <Prompt> ^ <Command> ~ <Data>< CR>

Base Unit passes it to the terminal. If terminal receives it successfully, an ACK will be send to the Base Unit. Base Unit passes the ACK to the Host. Otherwise, the Host may receive a NAK.

- <SOT> is ASCII 2.
- n is terminal ID, can be from 1 to 8.
- M is the current Prompt ID from host, you may defined the prompt ID to keep track of the status of the terminal.
- <Prompt> is the message and prompt you want to display on terminal to instruct the operator what to do next. You may specify on which line the message to be displayed using @mPrompt, m is the line number. Or using @Cm to clear line m. Please refer to 4.2 for detail.

- ^ is to separate the Prompt Text field and Command field
- <Command> is to instruct terminal to do certain things. Please refer to 4.2 for detail.
- ~ is to separate the Command field and Data field
- <Data> will be display with Prompt and can be modified. Usually, you send the default in the data field. If there is a P in the Command field, the terminal will send the Data to the serial printer.
- <CR> is the carriage return.

Terminal sends data to Host

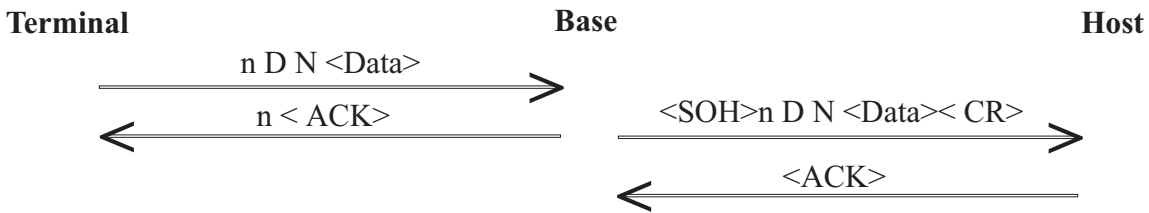

The data entered into RF-900 is sent to the Base unit. Base Unit will return an ACK. If RF-900 doesn't receive the ACK in 1/2 second, it will beep and display "OUT OF RANGE, HIT A KEY TO RETRY". When RF-900 receive the ACK, it will display "WAITING FOR PROMPT". If RF-900 doesn't receive the Prompt from the Host in the time period defined in Host Response Delay (See page 15), it will display "HOST NO RESPONSE, HIT A KEY TO RETRY"

Base Unit sends the log-in string starting with an ASCII 2 to the Host. The Host has to return an ACK right after receiving the string. Otherwise, the Base Unit will send again.

- n is terminal ID, can be from 1 to 8.
- D means data from the terminal
- N is the current Prompt ID from host, you may defined the prompt ID to keep track of the status of the terminal.
- <Data> is the data from the terminal.
- CR is the carriage return (ASCII 13)

Terminal log-out

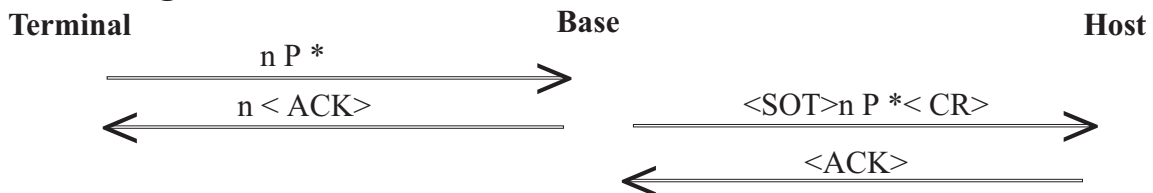

When finish using the RF-900, you may hit ESC key to get back to the Main Menu, or press Power key to turn off the RF-900. By doing so, RF-900 sends a log-out string to the Base unit.

Base Unit sends the log-in string starting with an ASCII 2 to the Host. The Host has to return an ACK right after receiving the string. Otherwise, the Base Unit will send again.

- n is terminal ID, can be from 1 to 8.
- <CR> is the carriage return.

Terminal request for prompt

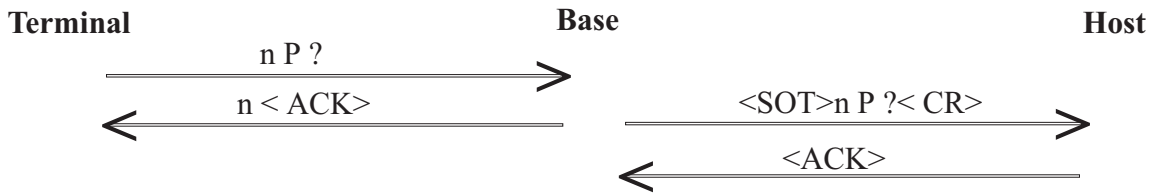

Usually, once the RF-900 receives the prompt/command from the Host, it will wait for user entering data or scanning bar code and will not receive another prompt/command from Host. But, if the Knn command is included in the prompt/command string, the terminal will send a n P? string if no data being entered in nn (00 - 99)second. With this feature, the Host may update certain information displayed on the terminal screen periodically.

n is terminal ID, can be from 1 to 8.

<CR> is the carriage return.

4.2 Host Prompt/Command

Host sends the Prompt/command string to the RF-900 as:

<SOT>n M <Prompt> ^ <Command> ~ <Data>< CR>

<SOT> is ASCII 2.

n is terminal ID, can be from 1 to 8.

M is the current Prompt ID from host, you may defined the prompt ID to keep track of the status of the terminal.

<Prompt> is the message and prompt you want to display on terminal to instruct the operator what to do next. You may specify on which line the message to be displayed using @mPrompt, m is the line number. Or using @Cm to clear line m.

^ is to separate the Prompt Text field and Command field

<Command> is to instruct terminal to do certain things.

~ is to separate the Command field and Data field

<Data> will be display with Prompt and can be modified. Usually, you send the default in the data field. If there is a P in the Command field, the terminal will send the Data to the serial printer.

<CR> is the carriage return.

4.2.1 Prompt

You may specify on which line the message to be displayed using @mPrompt, m is the line number, @Cm to clear line m, @C0 to clear the entire screen, and @Pmkk to position the cursor. A couple of example is given below for you to understand the prompt format.

<SOT>1A@C0@1Location:@2Item #:@4Qty.@P209^~<CR>

This will cause RF-900 to display as:

Location:

Item #: _

Qty:

<SOT>1B@3Bar Code Reader@P406^~1<CR>

This is sent after the previous prompt, which will cause RF-900 to display as:

Location:

Item #: SMX100 (SMX was entered by the operator)

Bar Code Reader

Qty: 1_

4.2.2 Command

We use Command to instruct terminal to do certain things. All the commands are listed as follow:

L, generating a low beep

M, generating a Medium beep

H, generating a High beep

A, Alphabetic data only which exclude 0-9.

N, Numeric data only which include 0-9, +, -, /, ., ans *.

P, output Data field to the printer

Tnn, Max. length of input data

Kxx,Keyboard input timeout in xx second

A couple of example is given below for you to understand the command format.

<SOT>1A@C0@1Location:@2Item #:@4Qty.@P209^MT08~<CR>

This will cause the terminal to generate a Medium beep and to limit the input data to 8 characters

<SOT>1B@3Bar Code Reader.@P406^HNK19~1<CR>

This will cause the terminal to generate a High beep, to limit the input data to numeric only, and to send a prompt request “n P?” if no data entered in 10 second.

4.3 Routine in VISUAL BASIC

1. Open COM Port

First, you need to place the ICON of the MSCOMM.VBX in the Form where the communication will be handled. Then use the following code to open the COM Port.

```
Comm1.CommPort = pn           'pn is COM port, can be 1,2,3 or 4
Comm1.Settings = "19200,N,8,1"
Comm1.InputLen = 0
Comm1.PortOpen = True
```

2. Send Prompt/Command/Data to the Terminal

```
Private Sub SENDDTA()
    C$ = Chr$(2) + ID$ + pid1$ + prompt$ + "^" + cmand$ + "~" + dta$ + Chr$(13)
    For j = 1 To (speed * 2000): j = j: Next j    'pid1$ is the prompt ID
SENDDTA1:                                     'Send string to COM port
    For M = 1 To Len(C$)
        Comm1.Output = Mid$(C$, M, 1)
        For j = 1 To (speed * 2000): j = j: Next j
    Next M

    B$ = ""
    j = speed * 100000
ESC28:
    Dummy = DoEvents()
    If Comm1.InBufferCount >= 1 Then GoTo ESC26
        j = j - 1
    If j = 0 Then rflag = 1: GoTo ENDD0 Else GoTo ESC28
ESC26:
    B$ = Comm1.Input
    If B$ = Chr$(6) Then rflag = 0: GoTo ENDD0
    If B$ = Chr$(21) Then rflag = 1: GoTo ENDD0
ENDD0:
End
```

3. Receive data from a Terminal

```
Private Sub RCV0()
```

```
    rflag = 0
```

```
    R$ = ""
```

```
RCVD1:
```

```
    B$ = ""
```

```
    j = speed * 30000
```

```
ESC22:
```

```
    Dummy = DoEvents()
```

```
    If Comm1.InBufferCount >= 1 Then GoTo ESC21
```

```
    j = j - 1
```

```
    If j = 0 Then rflag = 1: GoTo ENDD8 Else GoTo ESC22
```

```
ESC21:
```

```
    B$ = Comm1.Input
```

```
    R$ = R$ + B$
```

```
    If Right(R$, 1) = Chr$(13) Then
```

```
    If Left$(R$, 1) <> Chr$(2) Then rflag = 1: GoTo ENDD8
```

```
        R$ = Left$(R$, Len(R$) - 1)
```

```
        'Trim CR
```

```
        R$ = Right$(R$, Len(R$) - 1)
```

```
        'Trim chr$(2)
```

```
    If Left$(R$, 1) > "8" Or Left$(R$, 1) < "0" Then
```

```
        rflag = 1: GoTo ENDD8
```

```
    End If
```

```
        Comm1.Output = Chr$(6)
```

```
        GoTo ENDD8
```

```
    End If
```

```
        GoTo RCVD1
```

```
ENDD8:
```

```
End Sub
```

APPENDIX B SPECIFICATIONS

RF-2900

Range	up to 300 ft.
Frequency	900Mhz, Spread spectrum, Frequency hopping 4 selectable Network channels
Input Devices	Wand, CCD, Laser Scanner or Magstripe Reader
Display	4 x 20 LCD super twist display
Keypad	37-key alpha numeric, 4 user defined function keys
Bar Codes	Auto-discriminate between all the popular codes: Code 39, UPC/EAN, Codabar, Interleaved 2 of 5, MSI/Plessy and Code 128
Environmental	Operating temperature: 0 to 50 C
Relative humidity	up to 95% non-condense FCC Approved for unlicensed operation
Electrical	3 AA Alkaline or Ni-HM batteries
Physical	Length: 7.2 inches Width: 2.6 inch (hand grip) 3.5 inch (display) Depth: 1.35 inch (hand grip) 1.55 inch (display)
Weight:	14 Oz

Base Unit

Range	up to 300 ft., More coverage with satellite units
Frequency	900Mhz, Spread spectrum, Frequency hopping 4 selectable Network channels
Interface	RS-232 or RS-422 (4000 ft.)
RS-232 Option	9600 - 38400 Baud rate, 7 or 8 data bits, 1 or 2 stop bits, None, Odd, or Even parity
Environmental	Operating temperature: 0 to 50 C
Relative humidity	up to 95% non-condense FCC Approved for unlicensed operation
Electrical	9V / 110V unregulated AC adapter
Physical	Length: 6.25 inches Width: 4.375 inch Depth: 1.0 inch
Weight	16 Oz

APPENDIX C DESCRIPTION OF BAR CODE SYMBOLOGIES

The IBS-800 reader can read six bar code symbologies. A brief description of each symbology is given as follow:

1. UPC/EAN

UPC was established for the supermarket industry to facilitate automatic scanning of item number. You can see UPC labels on almost all grocery products and many retail items.

The character set of UPC/EAN consists of 10 digits: 0 - 9 and three special characters: Start, Center and Stop. The bars and spaces are integer multiples of the element or narrowest bar/space. The bars and spaces can vary from 1 - 4 elements in width. Each character is represented by two bars and two spaces containing a total of seven elements.

A UPC-A code contains 12 digits: the first digit is the NSC (number system character); the last digit is the checksum character. A UPC-E code contains 8 digits: the first digit is the NSC (number system character); the last digit is the checksum character. A EAN-13 code contains 13 digits: the first two digits are flags; the last digit is the checksum character. A EAN/8 code contains 8 digits: the first two digits are flags, the last digit is the checksum character.

The UPC/EAN standards include the addition of a 2 or 5 digit supplemental code used with magazines and paperback books.

2. Code 39 and Full ASCII Code 39

Code 39 has been widely accepted in manufacturing, hospitals, libraries, universities and government agencies. The US Department of Defense has adopted Code 39 as the DOD standard symbology.

Code 39 is so named because its character set originally consisted of 39 characters (now has 43). The name also derived from its 3 wide elements out of 9 elements. The start/stop character of Code 39 is "*".

A Mod 43 check digit can be added to the Code 39 for error detection. If you want to read Code 39 with a Mod 43 check digit, you need to enable the Mod 43 check digit when configuring the reader.

Full ASCII Code 39 expands the code 39 character set to include all 128 ASCII

characters. Symbols 0 - 9, A - Z and punctuation characters "." and "-" are the same as their representations in Code 39. Lower case letters, additional punctuation characters and control characters are represented by sequences of two characters in Code 39. Please see the following table:

	Code		Code		Code		Code
ASCII	39	ASCII	39	ASCII	39	ASCII	39
NUL	%U	SP	SP	@	%V	`	%W
SOH	\$A	!	/A	A	A	a	+A
STX	\$B	"	/B	B	B	b	+B
ETX	\$C	#	/C	C	C	c	+C
EOT	\$D	\$	/D	D	D	d	+D
ENQ	\$E	%	/E	E	E	e	+E
ACK	\$F	&	/F	F	F	f	+F
BEL	\$G	'	/G	G	G	g	+G
BS	\$H	(/H	H	H	h	+H
HT	\$I)	/I	I	I	i	+I
LF	\$J	*	/J	J	J	j	+J
VT	\$K	+	/K	K	K	k	+K
FF	\$L	,	/L	L	L	l	+L
CR	\$M	-	-	M	M	m	+M
SO	\$N	.	.	N	N	n	+N
SI	\$O	/	/O	O	O	o	+O
DLE	\$P	0	0	P	P	p	+P
DC1	\$Q	1	1	Q	Q	q	+Q
DC2	\$R	2	2	R	R	r	+R
DC3	\$S	3	3	S	S	s	+S
DC4	\$T	4	4	T	T	t	+T
NAK	\$U	5	5	U	U	u	+U
SYN	\$V	6	6	V	V	v	+V
ETB	\$W	7	7	W	W	w	+W
CAN	\$X	8	8	X	X	x	+X
EM	\$Y	9	9	Y	Y	y	+Y
SUB	\$Z	:	/Z	Z	Z	z	+Z
ESC	%A	;	%F	[%K	}	%P
FS	%B	<	%G	\	%L		%Q
GS	%C	=	%H]	%M	{	%R
RS	%D	>	%I	^	%N	~	%S
US	%E	?	%J	_	%O	DEL	%T

Accumulate mode allows you to accumulate multiple bar codes in the reader's buffer then transmit them to the computer at one time. When the reader reads a bar code with a leading space, it beeps and buffers the data. It keeps on reading and buffering the data until it reads a bar code without a leading space. Then the entire buffer will be transmitted to the computer. Wanding clear buffer (--) will clear all the data in the buffer. Wanding backspace (\$H) will delete previous character.

3. Interleaved 2 of 5

Interleaved 2 of 5 has been widely accepted as a numeric bar code symbol in warehousing and heavy industrial applications.

The character set of Interleave 2 of 5 consists of 10 digits: 0 - 9. Each digit is represented by five elements: two wide and three narrow. The odd numbered digits are represented in the bars, and even numbered digits are represented in the spaces. The start character consists of narrow bar, narrow space, narrow bar, narrow space. The stop character consists of wide bar, narrow spaces, narrow bar.

Interleaved 2 of 5 bar code symbology is susceptible to partial read. We can set the length of code to avoid a partial read.

A check digit can be added to the Interleaved 2 of 5 for error detection. If you want to read the Interleaved 2 of 5 with a check digit, you need to enable the check digit when configuring the reader.

4. Codabar

Codabar has been most widely accepted in libraries and medical applications. It has also been extensively used for photo finishing envelopes and preprinting air bills. It has been adopted by the American Blood Commission as a standard for blood bags.

The character set of Codabar consists of 16 characters: 0 - 9, +, -, :, ., / and \$. Four different start/stop characters are defined: a, b, c and d. Each character is represented by 4 bars and 3 included spaces.

Codabar is variable length and self-checking, making it a versatile and very low error rate bar code symbology.

5. Code 128

Code 128 was named for its capability of encoding the full ASCII 128 character set. It is a variable length and self-checking bar code symbology.

Each Code 128 character consists of three spaces and three bars, with each space or bar containing one to four elements. The total elements for each character is eleven. There are two levels of error checking in Code 128: for each character, character parity is defined by the sum of the elements of bars being even and the sum of the elements of spaces being odd; for each bar code label, a modules 103 check character is implemented.

6. MSI/Plessey

The character set of MSI/Plessey consists of 10 numeric characters. Each character is represented by 4 bars and 4 spaces.

One or two check digits need to be add to the MSI/Plessey code for error detection. You need to enable one or two check digits when configuring the reader.

APPENDIX D PINOUT OF THE HOST PORT

Pin	RS-232
1	
2	Transmit data
3	Received data
4	
5	GND
6	
7	
8	
9	